

## Journal of Religious and Social Studies

<http://ejrss.com/index.php/jrss>

ISSN (Print): 2789-0317

ISSN (online): 2789-0325

School of Religious and Social Studies,  
Faisalabad (38000), Pakistan.

---

# Development and Validation of a Composite Short Scale for Measuring Socially Distant Attitudes toward Religious Minorities in Pakistan

Khaista Rahman, Muhammad Tahir Khalily, and Muhammad Akram

To cite this article:

Khaista Rahman, Muhammad Tahir Khalily, and Muhammad Akram. "Development and Validation of a Composite Short Scale for Measuring Socially Distant Attitudes toward Religious Minorities in Pakistan." *Journal of Religious and Social Studies* 3, no. 2 (2023): 60-81.

DOI: <https://doi.org/10.53583/jrss06.04.2023>



*Scan for the Issue*

Full Terms & Conditions of access and licensing can be found at:  
<http://ejrss.com/index.php/jrss/policies>



## DEVELOPMENT AND VALIDATION OF A COMPOSITE SHORT SCALE FOR MEASURING SOCIALLY DISTANT ATTITUDES TOWARD RELIGIOUS MINORITIES IN PAKISTAN

Khaista Rahman<sup>1</sup>, Muhammad Tahir Khalily<sup>2</sup>, Muhammad Akram<sup>3</sup>

**Abstract:** The literature extensively explores Muslim students' attitudes towards religious minorities in Pakistan. However, most of these studies are qualitative, leaving a notable gap in the availability of self-report measures to capture genuine opinions. Furthermore, existing quantitative studies rely on simple questionnaires rather than rigorously developed and validated scales. This study addresses this gap by developing and validating an objective composite scale for measuring attitudes toward religious minorities in Pakistan. We began by creating a pool of 50 items, some adapted from existing scales and others newly created. This pool underwent careful scrutiny and discussions, resulting in a refined collection of 27 items. The reduced item pool was first piloted and then administered to a sample of university students (Sample 1, n=300) for exploratory factor analysis that resulted in a unidimensional seven-item scale named "Socially Distant Attitude towards Religious Minorities" with a Cronbach's  $\alpha$  of 0.87. Subsequently, confirmatory factor analysis (Sample 2, n=498) demonstrated satisfactory construct validity, as indicated by robust model fit indices: Root Mean Squared Error Approximation (RMSEA) = 0.07, Goodness of Fit Index (GFI) = 0.98, Comparative Fit Index (CFI) = 0.98, Normative Fit Index (NFI) = 0.97, Tucker Lewis Index (TLI) = 0.96, and  $p < 0.001$ . The resulting composite scale holds promise for future

<sup>1</sup> Lecturer, Pakistan International School Doha, Qatar. Email: [krshahabiiui@gmail.com](mailto:krshahabiiui@gmail.com).

<sup>2</sup> Dean Faculty of Social Sciences and Humanities, Shifa Tameer-e-Millat University Islamabad and Academic Fellow Department of Neurosciences, School of Medical Sciences, Universiti Sains Malaysia. Email: [dr.khalily@iiu.edu.pk](mailto:dr.khalily@iiu.edu.pk).

<sup>3</sup> Head Department of the Study of Religions, International Islamic University, Islamabad, Pakistan. Email: [m.akram@iiu.edu.pk](mailto:m.akram@iiu.edu.pk).

research endeavours, and its application in subsequent studies will further validate its utility and reliability.

**Keywords:** *Composite Scale, Socially Distant Attitude, Religious Minorities, Scale Adaptation, Psychometrics, Pakistan.*

## 1. INTRODUCTION

Pakistan, a nation characterized by its rich tapestry of cultures, languages, ethnicities, religions, and sects, hosts a diverse population that includes significant religious minorities, notably Christians and Hindus. According to the 2017 Census,<sup>1</sup> these religious minorities constitute 3.72% of the country's population. Pakistan's constitution, as stipulated in Article 20, safeguards the rights of all citizens, ensuring equality regardless of religious affiliation and the freedom to practice and propagate their chosen religion.<sup>2</sup>

However, disparities between legal principles and ground realities persist despite constitutional safeguards. A notable instance is the 2014 report by the Pew Research Center, which included Pakistan in the list of nations hostile to religious minorities. This contrasted with the government's perspective, attributing tensions to broader security challenges following 9/11. The disparities, however, have been attributed to various factors, including specific policies, stereotypes within the judicial system, class-based education, unrelenting media portrayals, and an unjust social system.<sup>3</sup>

---

<sup>1</sup> Pakistan Bureau of Statistics. Population by Religion. Islamabad: Pakistan Bureau of Statistics, 2017. Retrieved November 6, 2023, from <https://www.pbs.gov.pk/content/final-results-census-2017-0>

<sup>2</sup> Iram Khalid, and Maqbool Anwar. "Minorities under Constitution(s) of Pakistan." *Journal of Research Society of Pakistan* 55, no. 2 (2018): 51-62; Mustafa, Ahmad, and Arslan. "Minorities of Pakistan: An Analytical Analysis of the 1973 Constitution of Islamic Republic of Pakistan." *Pakistan Social Sciences Review* 4, no. 2 (2020): 736-750.

<sup>3</sup> Shaun R. Gregory, and Simon R Valentine. *Pakistan: The Situation of Religious Minorities*. Geneva: United Nations High Commissioner for Refugees, 2009, 1-41; Mughal. "On the Catalogue of Injuries Faced by Religious Minorities in Pakistan." *Open Democracy*. January 25, 2018. [Link](#) (accessed March 12, 2023); Fuchs and Fuchs. "Religious Minorities

Issues within the judicial system, such as a socially unfriendly attitude towards religious minorities, have been reported, and the blasphemy law, though debated, has been criticized for its potential adverse impact on religious minorities and attitudes toward them.<sup>1</sup>

The education system also plays a role in perpetuating prejudices, with minorities facing lower access to quality education and biased curriculum representation.<sup>2,3</sup> According to the United States Commission on International Religious Freedom, the curriculum sometimes portrays religious minorities negatively.<sup>4</sup>

Attitudes of Muslim students towards religious minorities vary but often lean towards intolerance, particularly in Urdu medium schools.<sup>5</sup> Bias within public schools towards students from religious minority backgrounds has led to segregation during lunch periods.<sup>6</sup>

---

in Pakistan: Identities, Citizenship and Social Belonging." *South Asia: Journal of South Asian Studies* 43, no. 1 (2020): 52-67.

<sup>1</sup> Hina Shaikh. *Status of Minorities in Pakistan in 2010: Annual Report*. Colombo: South Asians for Human Rights, 2011.; Pakistan Institute of Labour Education & Research. *The Choice of Reforms: The Human Rights Situation of Ethnic, Linguistic, Religious Minorities, Scheduled Castes Hindus and Indigenous people in Pakistan*. Karachi: Pakistan Institute of Labour Education & Research, 2009; Poza. "Pakistan's Institutionalized Discrimination Against Religious Minorities." *Huff Post*. May 25, 2011. [Link](#) (accessed March 8, 2023).

<sup>2</sup> Poza. "Pakistan's Institutionalized Discrimination Against Religious Minorities." [Link](#)

<sup>3</sup> Islamabad Policy Research Institute. *Rights of Religious Minorities in South Asia: Learning from Mutual Experiences*. Islamabad: Islamabad Policy Research Institute, 2012.

<sup>4</sup> United States Commission on International Religious Freedom. "USCIRF Annual Report 2016 - Tier 1 CPC recommended by USCIRF-Pakistan." *Refworld*. May 2, 2016. [Link](#) (accessed Nov 25, 2023).

<sup>5</sup> Raheem. "A comparative study of the attitudes of students attending Urdu Medium, English Medium and Seminary Schools in Pakistan." pp. 120-140; Ajmal, Sultana, Tahira. "Perception of Pakistani Muslim Students Regarding Jews." *Pakistan Journal of Social and Clinical Psychology* 9 (2011): 3-10; Tariq. "Pluralism and Intolerance in Pakistani Society: Attitudes of Pakistani Students towards Other Religious." *Conference on Pluralism*. Karachi: Aga Khan University Institute for the Study of Muslim Civilization, 2003.

<sup>6</sup> Zafar ul-Islam Mehmood, Munawar S Mirza, Khuda Bakhsh Khan, Muhammad Shahbir, and Sagheer Iqbal. "Discrimination and Problems of Religious Minority Students in

Madrasa (religious seminary) education has been implicated in shaping students' attitudes, with textbooks often portraying non-Muslims negatively.<sup>1</sup> In some cases, Madrasa students exhibit more intolerant attitudes than their peers in mainstream schools.<sup>2</sup>

Media coverage of minorities has been criticized for being stereotypical and unsympathetic. However, certain English newspapers offer positive representations.<sup>3</sup> Private TV and social media platforms have raised awareness about minority rights,<sup>4</sup> though there are diverse opinions on their impact.<sup>5</sup> The impact of these societal attitudes

---

Public Schools of Pakistan." *Journal of Education Research and Behavioral Sciences* 3, no. 8 (2014): 237-239; Mughal. "On the Catalogue of Injuries Faced by Religious Minorities in Pakistan." *Open Democracy*. January 25, 2018. [Link](#) (accessed March 12, 2023).

<sup>1</sup> Kamran Chaudhry. "Minorities' Marginalized by Pakistan's Media." *Union of Catholic Asian News*. February 05, 2019. [Link](#) (accessed February 10, 2023).

<sup>2</sup> Raheem, "A Comparative Study of the Attitudes of Students Attending Urdu Medium, English Medium and Seminary Schools in Pakistan" pp. 120-140.

<sup>3</sup> Zeeshan Ali Khan. "Media Coverage Provided to Religious Minorities: A Study on Pakistani Print Media Since 2011 to 2015." *International Journal of Applied Sciences* 1, no. 4 (2016): 30-44; Ambreen. "Representation of Religious Minorities in Pakistani Print Media: A study of Daily Dawn, The News, and The Nation." *American International Journal of Contemporary Research*, 2014: 140-156; Ali, and Jalaluddin. "Portrayal of Minorities in Elite English press of Pakistan: A study of *Daily Dawn* and *The Nation*." *Pakistan Journal of Social Sciences* 30, no. 1 (2010): 141-156.

<sup>4</sup> Amber Mubeen, and Rabia Qusien. "Minorities in Pakistan: Role of Pakistani Private TV Channels in Highlighting Minorities' Rights." *Online Journal of Communication and Media Technologies* 7, no. 2 (2017): 96-103; Bushra. "Cue the Curtain on Pakistani Minorities." *The Dawn*. August 3, 2011. [Link](#) (accessed March 10, 2023).

<sup>5</sup> Kashif Anthony, and Zahid Hussain. "Social Media Stoking Religious Hatred in Pakistan." *Union of Catholic Asian News*. September 17, 2018. [Link](#) (accessed March 10, 2023); Tanveer. "Social Media being used as tool against Minorities." *The Express Tribune*. December 22, 2016. [Link](#) (accessed May 10, 2023); Tamsut. "Pakistanis stand with persecuted minority on social media." *DW Akademie*. December 2, 2015. [Link](#) (accessed May 10, 2023).

is reflected in the educational outcomes and mental health of religious minority individuals.<sup>1</sup>

Despite the extensive literature on attitudes towards religious minorities in Pakistan, there is a paucity of valid and reliable measures. Existing studies often rely on qualitative methods or simple questionnaires without using confirmatory analysis. While some studies have utilized qualitative methods or simple questionnaires, the absence of valid and reliable scales limits the depth and accuracy of our understanding. The need for a dedicated short scale becomes even more apparent comparing existing instruments, such as the "Attitudes towards Blacks" Scale by John C. Brigham, which, despite its reliability, cannot be directly applied to measure attitudes towards religious minorities in Pakistan. This scale, with 20 items and a Cronbach's alpha coefficient of 0.82, was specifically designed to measure attitudes toward Black individuals in the context of the Netherlands. While this scale captures general attitudes and prejudices, it is imperative to recognize that attitudes towards racial and ethnic minorities can significantly vary based on cultural, contextual, and historical factors. The focus on ethnic majorities and minorities within the Dutch context limits the applicability of this scale to measure attitudes towards religious minorities in Pakistan.<sup>2</sup>

The Lain Walker's "Attitudes to Aborigines Scale" scale specifically assesses attitudes towards Aborigines in Australia. The scale consists of items that reflect a range of attitudes, from negative stereotypes to positive perceptions. These items may not

---

<sup>1</sup> Fouzia Naveed, Maryam Munir, and Yasir Saeed. "Unveiling the Situation of Religious Minorities: A Case Study of Marginalized Groups Living in Lahore." *International Journal of Asian Social Science* 4, no. 1 (2014): 41-50; Isik. Factors Influencing Academic Motivation of Ethnic Minority Students: A Review." *Sage Open Journal*, 8(2), (2018): 1-23. doi:2158244018785412; Iqbal and Ayub. "Self-esteem: A Comparative Study of Adolescents from Mainstream and Minority Religious Groups in Pakistan." *Journal of Immigrant and Minority Health* 15, no. 1 (2013): 49-56; Iqbal, Ahmad, and Ayub. "Level of Depression among Adolescents of Religious Minorities and their Dominant Counterparts in Pakistan." *Journal of Child and Adolescent Mental Health* 24, no. 2 (2012): 163-171.

<sup>2</sup> John C Brigham. "College Students' Racial Attitudes." *Journal of Applied Social Psychology*, no. 23 (1993): 1933 - 1967.

capture the complex interplay of factors influencing attitudes towards religious minorities in Pakistan, where religious beliefs and practices play a more prominent role.

Similarly, another scale, "Attitudes to Asians Scale," developed by Walker, provides an insight into attitudes towards Asians in the Australian context. The scale is inherently tailored to assess attitudes related to race and ethnicity, particularly in the context of immigration. Like the Attitudes to Aborigines Scale, this scale is culturally specific to Australia and may not directly apply to measuring attitudes towards religious minorities in Pakistan. Thus, its applicability to measuring attitudes toward religious minorities in Pakistan is limited, given the distinct cultural, historical, and religious contexts of both populations.<sup>1</sup>

Muhammad Arslan Raheem's questionnaire, on the other hand, seems to primarily address the status of religious minorities in Pakistan rather than the majority's attitudes towards them. While valuable for comprehending the situation and conditions of minorities, it may not fully capture the nuanced and subjective aspects of attitudes towards religious minorities.<sup>2</sup>

Consequently, there is a pressing need for a valid and reliable instrument to assess attitudes towards religious minorities in Pakistan systematically. Our study endeavours to develop and validate a short-scale drawing from adapted and newly created items to address this gap. We present this scale's process, reliability, and validity, applying exploratory and confirmatory factor analyses to different samples.

## 2. METHODS

The scale development process consists of nine steps.<sup>3</sup> Some have suggested a minimum of five stages of scale development, endorsed by an overwhelming majority

---

<sup>1</sup> Lain Walker. "Attitudes to Minorities: Survey Evidence of Western Australians' Attitudes to Aborigines, Asians, and Women." *Australian Journal of Psychology* 46, no. 3 (1994): 137-143.

<sup>2</sup> Raheem, "A Comparative Study of the Attitudes of Students Attending Urdu Medium, English Medium and Seminary Schools in Pakistan" 2015., 136-136.

<sup>3</sup> Godfred O. Boateng, Torsten B. Neilands, Edward A. Frongillo, Hugo R. Melgar-Quinonez and Sera L. Young. "Best Practices for Developing and Validating Scales for

of scholars.<sup>1</sup> These five steps are (1) Identification of the domain of the construct, (2) Creation of the Item pool, (3) Response format, (4) Selection and revision of the items, and (5) Evaluation of the psychometric properties of the scale. We have followed these steps in this study to develop the proposed scale.

## 2.1 ITEM ADAPTATION AND CREATION

The initial stage of our scale development and adaptation encountered a significant challenge in precisely defining the domain of the construct. The existing literature predominantly highlighted negative social attitudes towards religious minorities in Pakistan, creating ambiguity in the conceptualization.

We strategically focused on the specific facet of social attitudes to address this challenge, narrowing our domain to “socially distant attitudes.” This refinement allowed us to align the scale with the prevalent sentiments identified in the literature, ensuring clarity and relevance. We used a deductive method for item’ generation. As Boateng et al. suggested, the items are identified with the help of relevant literature and the relevant domain’s existing scales.<sup>2</sup> Thus, we reviewed the existent scales and literature on attitudes toward religious minorities. We adapted six items from the “Attitudes towards Blacks” scale,<sup>3</sup> eight items from the “Attitudes to Aborigines Scale,”<sup>4</sup> four items from the Unfavourable Attitudes towards ethnic minorities scale,<sup>5</sup> three items from Raheem’s

---

Health, Social, and Behavioral Research: A Primer." *Front Public Health*, no. 6: 149 (June 2018): 1-18.

<sup>1</sup> Robert F DeVellis. *Scale Development: Theory and Applications*. (Los Angeles: SAGE Publications, 2017); Furr. *Scale Construction and Psychometrics for Social and Personality Psychology*. (New Delhi: Sage Publications, 2011).

<sup>2</sup> Boateng. "Best Practices for Developing and Validating Scales for Health, Social, and Behavioral Research: A Primer." 1-18.

<sup>3</sup> Brigham. "College Students' Racial Attitudes.": 1933 - 1967.

<sup>4</sup> Walker. "Attitudes to Minorities: Survey Evidence of Western Australians' Attitudes to Aborigines, Asians, and Women.": 137-143.

<sup>5</sup> GenevieÁ ve Verberk, Peer Scheepers, and Albert Felling. "Attitudes and Behavioural Intentions towards Ethnic Minorities: An Empirical Test of Several Theoretical Explanations for the Dutch Case." *Journal of Ethnic and Migration Studies* 28, no. 2 (April 2002): 197-219.



questionnaire on the status of non-Muslims in Pakistani society and created 29 items making the total of 50 items pool. After careful consideration, the item pool was refined to 29 items by removing the complex and ambiguous items following the suggestion of Clark and Watson.<sup>1</sup>

## 2.2 MODIFICATION AND PILOTING OF THE ITEMS

During the item modification and piloting phase, the challenge of delimiting the domain persisted due to the pervasive negativity in the existing literature. Additional effort was made to simplify the wording of the items and incorporate the attitudinal focus. Afterward, the initial pool of 50 items underwent thorough discussion and deliberation involving experts from the Department of Psychology, International Islamic University, Islamabad, to address face validity.<sup>2</sup> Following expert opinions, 20 items were removed, and a Likert-type rating response format with five options, ranging from 'strongly agree' to 'strongly disagree,' was chosen for the final set of 30 items following the suggestion of Clark and Watson.<sup>3</sup> This refined pool was then piloted on a small sample of 30 respondents to enhance item clarity and understanding. The iterative process led to finalizing 27 items designed to represent attitudes toward religious minorities.

## 2.3 ADMINISTRATION OF THE ITEMS

The final 27 items, demographic questions, and a consent form were randomly distributed among 315 students (sample 1) from various universities in Islamabad, including IIUI, Quaid Azam University, Bahria University, and National Defence

---

<sup>1</sup> Lee Anna Clark, and David Watson. "Constructing Validity: Basic Issues in Objective Scale Development." *The American Psychological Association* 7, no. 3 (1995): 309-319.

<sup>2</sup> A. Parasuraman, V. Zeithaml, and A. Malhotra. "E-S-Qual: A Multiple-item scale for Assessing Electronic Service Quality." *Journal of Service Research*, Vol.7, No.3, 7, no. 3 (2005): 213-233; Urbina. *Essentials of Psychological Testing*. New Jersey: John Wiley & Sons, Inc, 2004.

<sup>3</sup> Clark and Watson. "Constructing Validity: Basic Issues in Objective Scale Development." 309-319.

University. This distribution followed the recommendation of Clark and Watson (1995)<sup>1</sup> for exploratory factor analysis. However, it is noteworthy to mention that we encountered challenges during this phase. Communicating the purpose of the survey proved to be challenging, and there was a notable difficulty in explaining the study's objectives to the respondents. Additionally, the survey completion process spanned 15 days, introducing another layer of complexity. Notably, 15 forms were deemed incomplete and, consequently, were excluded from the analysis.

### 3. RESULTS

#### 3.1 SAMPLE 1 CHARACTERISTICS

Out of 300, 152 were male respondents, and 148 were female. Two hundred eight students were enrolled in BS, 71 in MS, and 12 in PhD programs. The majority of students were Punjabi (57%), followed by Pakhtun (31.6%), Baloch (5.2%), Sindhi (4.5%), and others<sup>2</sup> (1.7%). Sample 1 was denominationally diverse. One hundred eighteen students belonged to Deobandi school of thought, 91 to Barelvi, 50 Ahl-e-Hadith, 20 Shi'a, and 14 to the 'other' category.<sup>3</sup>

#### 3.2 FINALIZATION OF FACTOR STRUCTURE

EFA (SPSS-25) was performed to know the scale's dimensionality,<sup>4</sup> which is crucial for scale development.<sup>5</sup> The researchers conducted the common factor analysis, also known as Principal Axis Factoring,<sup>6</sup> by following the recommendation of DeVellis, as it

---

<sup>1</sup> Clark and Watson. "Constructing Validity: Basic Issues in Objective Scale Development." 309-319.

<sup>2</sup> Saraiki, Chitralli, Hindko, and Kashmiri.

<sup>3</sup> Other categories included those who claimed to be just Muslims, Salafi, and Hanafi.

<sup>4</sup> Furr. *Scale Construction and Psychometrics for Social and Personality Psychology*.

<sup>5</sup> DeVellis. *Scale Development: Theory and Applications*.

<sup>6</sup> R. B. Keline. "Exploratory and Confirmatory Factor Analysis." In *Applied Quantitative Analysis in Education and Social Sciences*, edited by C. Schatschneider and D. L. Compton Y. Petscher, 171-207. (New York: Routledge, 2013).

focuses only on the variance that is common or shared among items, excluding variance that is unique to any specific item.

The Kaiser-Meyer-Olkin called KMO, and Bartlett's Test of Sphericity were followed to check sample suitability for factor analysis. The score for KMO was 0.89, fulfilling Kaiser's recommendation.<sup>1</sup> Similarly, Bartlett's Test of Sphericity was also statistically significant ( $p < 0.001$ ).

**Table 1:** KMO and Bartlett's Test

Kaiser-Meyer-Olkin Measure of Sampling Adequacy.		.89
Bartlett's Test of Sphericity	Approx. Chi-Square	862.61
	df	21
	Sig.	.000

Accordingly, we used a common factor analysis with orthogonal rotation (varimax) to assess the scale of the 27 items. The factors were retained following the rule of Eigenvalue, according to which the factors less than 1.0 should be dropped.<sup>2</sup> The initial factor analysis revealed a four-factor solution by following the Eigenvalue rule. However, most of the items of factors 2, 3, and 4 were strongly cross-loaded, and their commonality values were below 0.2.

Only seven items were highly loaded on factor 1 and four items on factor 2 with no cross-loadings, fulfilling the benchmark between 0.3 to 0.4, as recommended.<sup>3</sup> These two factors explained 45.9 % of the total variance. However, in reliability analysis, factor 2 demonstrated poor estimates of less than 0.60. Thus, the single factor was taken, which

<sup>1</sup> Henry F. Kaiser. "An index of Factorial Simplicity." *Psychometrika*, no. 39 (1974): 31–36.

<sup>2</sup> DeVellis. *Scale Development: Theory and Applications*.

<sup>3</sup> Noor Ul Hadi, Abdullah, Naziruddin. and Ilham Sentosa. "An Easy Approach to Exploratory Factor Analysis: Marketing Perspective." *Journal of Educational and Social Research* 6, no. 1 (2016): 215-223; Hair, Black, Babin and Anderson. *Multivariate Data Analysis*. 7th. (Edinburgh: Pearson Education Limited, 2014).

explained 49.7% of the total variance. These items were retained because they loaded primarily on factor 1 without any cross loadings, as suggested by DeVellis.<sup>1</sup>

**Table 2:** Factor Matrix

Items	Factor loading	Communalities
1. I would not like to invite people belonging to religious minority groups to any social gathering organized by me.	.77	.59
2. People belonging to religious minorities always pursue their interests and not the interests of the country they live in.	.76	.57
3. I would not like to attend a social gathering organized by people who belong to religious minority groups.	.73	.54
4. People belonging to religious minorities have the backing of foreign and unfriendly countries.	.72	.52
5. If any member of religious minorities sat next to me on a bus or train, I would feel uncomfortable.	.70	.50
6. I think there should be different schools for non-Muslim students in Pakistan.	.64	.41
7. When I come into contact with religious minority groups, I am cautious what I say as they are not our friends.	.60	.36

### 3.4 RELIABILITY ANALYSIS

Reliability is an essential condition for the scale's evaluation. It demonstrates the internal consistency of a scale.<sup>2</sup> A commonly used method is the measurement of Cronbach's alpha coefficient. The alpha coefficient value below 0.60 shows poor reliability; above 0.70 is the recommended value.<sup>3</sup> Common factor analysis revealed a

<sup>1</sup> DeVellis. *Scale Development: Theory and Applications*.

<sup>2</sup> William G. Zikmund, Barry J. Babin, Jon C. Carr, and Mitch Griffin. *Business Research Methods*. 9th. (Boston: Cengage Learning, 2013).

<sup>3</sup> Zikmund. *Business Research Methods*.

two-factor solution. Nonetheless, the second factor showed abysmal reliability and lowered the alpha coefficient below 0.6 of both factors. Therefore, only a single factor was retained. As shown below in Table 3, Cronbach’s alpha exceeded the desired value for a single factor.

**Table 3: Reliability Statistics**

Cronbach’s Alpha	N of Items
.87	7

Table 4 shows the Cronbach alpha if an item is to be deleted. It also reveals the mean for the seven-item unidimensional scale. All the items showed reasonable reliability, ranging from 0.84 to 0.86. In short, the total estimated alpha, which is 0.87, exceeded the “alpha if item deleted,” so there was no need to drop any item. The single-factor unidimensional scale was named the Socially Distant Attitude Towards Religious Minorities Scale (SDATRM).

**Table 4: Item-Total Statistics**

Items	Scale Mean if Item Deleted	Scale Variance if Item Deleted	Corrected Item-Total Correlation	Cronbach’s Alpha if Item Deleted
I would not like to attend a social gathering organized by people who belong to religious minority groups.	18.80	29.87	.68	.85
People belonging to religious minorities always pursue their interests and not the interests of the country they live in.	18.77	30.84	.70	.85
People belonging to religious minorities have the backing of foreign and unfriendly countries.	19.02	31.57	.67	.85

If any member of religious minorities sat next to me on a bus or train, I would feel uncomfortable.	18.49	30.09	.65	.85
I would not like to invite people belonging to religious minority groups to any social gathering organized by me.	18.59	29.65	.71	.84
I think there should be different schools for non-Muslim students in Pakistan.	18.71	30.60	.59	.86
When I come into contact with religious minority groups, I am cautious about what I say as they are not our friends.	19.07	31.74	.56	.86

#### 4. VALIDATION OF THE SDATRM SCALE

EFA was followed by the CFA (AMOS-22) to analyze the validity. For this purpose, completely new data (sample 2, n=498) of university students was used as the same data may not give informative and accurate results. Thus, following the recommendation of the new data set for CFA,<sup>1</sup> this study used two separate samples. Participants of sample 2 consisted of 321 (64.5%) male and 177 (35.5%) female students. Three hundred fifty-four students were enrolled in BS, 121 in MS, and 23 in PhD programs. The majority of students were Punjabi (52.6%), followed by Pakhtun (32.9%), other<sup>2</sup> (13.1%), Sindhi (1.2%), and Baloch (.2%).

The CFA was conducted on the single factor seven items, based on the results of EFA. The CFA results showed that the standardized regression weights were above 0.50, indicating the acceptability of the items. Four error variables, e1, e2, and e2, e4, were slightly co-varied as they were similar in representing the socially distant attitude. Model fit indices revealed a good fit with  $\chi^2 (12) = 39.44$ ;  $\chi^2 / df = 3.3$ ; root mean square error of approximation (RMSEA) = .07; goodness-of-fit index (GFI) = .98; Tucker-Lewis

<sup>1</sup> Robin K. Henson, and J. Kyle Roberts. "Use of Exploratory Factor Analysis in Published Research: Common Errors and Some Comment on Improved Practice." *Educational and Psychological Measurement* 66, no. 3 (2006): 393–416.

<sup>2</sup> Saraiki, Chitrali, Hindko, and Kashmiri.

index (TLI) = .96; confirmatory fit index (CFI) = .98; normed fit index (NFI) = .97 and  $p < 0.001$ .

**Table 5:** CFA of SDATRM<sup>a</sup>

Name of Fit Index		Value	Threshold value	Remarks
<b>GFI</b>		.98	A value closer to 1 is regarded as a good fit.	Good fit
<b>RMSEA</b>		.07	A value less than 0.08 is regarded as a good fit.	Good fit
<b>TLI</b>		.96	$\geq 0.90$	Good fit
<b>CFI</b>		.98	$\geq 0.90$	Good fit
<b>NFI</b>		.97	$\geq 0.90$	Good fit
<b>Normed Chi-Square</b>		3.3	Range from 1-5.	Good fit

<sup>a</sup>= Socially Distant Attitudes towards Religious Minorities

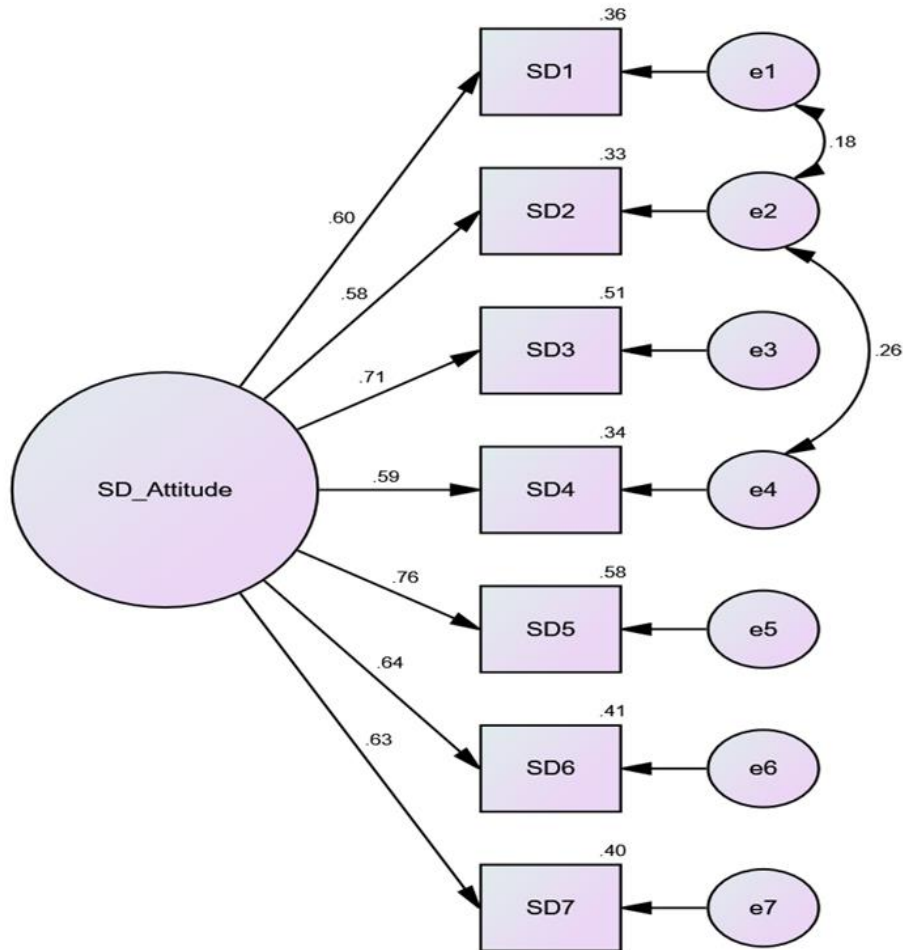

Figure 1: CFA of SDATRM Scale

## 5. DISCUSSION

The purpose of this study was to develop a reliable scale to measure the attitudes towards religious minorities in Pakistan. The process was set into four main stages. In



the first stage, relevant literature and scales were reviewed. A 50-item pool was created and critically examined in the second stage. In the third stage, we performed EFA to find the factor structure and internal consistency by using the alpha coefficient. In step four, we explored the construct validity using the CFA technique.

EFA was used to reduce the set of items into interpretable factors and to assess the validity of the attitude scale. KMO and the Bartlett Sphericity tests were used to examine the suitability of data for factor analysis. In EFA, the common factor technique was used. The reliability of the scale was assessed by calculating Cronbach's alpha coefficient. Afterward, CFA was used to test the resultant structure of the scale and its validity.

Consequently, this study established the psychometric properties of the Socially Distant Attitude Towards Religious Minorities Scale (SDATRM). The analysis revealed satisfactory reliability and validity of SDATRM. Analysis of 27 items discovered a single factor with seven items, which explained 49.7% of the total variance. All the items were loaded on a single factor with loadings more than 0.60. All the communalities values were above 0.30. Internal consistency was confirmed as the Cronbach Alpha coefficient was 0.87.

The high communalities and factor loadings observed in the SDATRM have significant implications for interpreting the scale's items. Communalities represent the proportion of each variable's variance explained by the common factors. In our study, the communalities for all items were notably high, ranging from 0.36 to 0.59 (Table 2). This indicates that the underlying factor accounts for a substantial portion of the variance in each item, suggesting a robust association between the observed variables and the latent construct of socially distant attitudes towards religious minorities. The high communalities reinforce the scale's reliability and affirm that the selected items effectively capture the intended construct.

Furthermore, the factor loadings provide insight into the strength and direction of the relationships between each item and the underlying factor. In Table 2, factor loadings ranged from 0.60 to 0.77, signifying a robust association between the individual items and the overarching construct of socially distant attitudes. Notably, all items loaded significantly on the single factor, emphasizing the unidimensional nature of the scale. The high factor loadings underscore the coherence of the items in measuring the same underlying construct. Consequently, these findings support the validity of the SDATRM

as a reliable tool for assessing socially distant attitudes towards religious minorities, as the items collectively contribute to a comprehensive understanding of the targeted construct.

The CFA followed the EFA. The model fit indices suggested a good fit. The  $p$ -value was significant ( $p < 0.001$ ). The value of RMSEA was less than 0.08.<sup>1</sup> Chin and Todd (1995)<sup>2</sup> suggest the value of GFI is more than 0.90, which was 0.98. The CFI value was 0.98, exceeding the 0.90 cut-offs proposed by Kline.<sup>3</sup> NFI was 0.97, greater than the Bentler and Bonnet<sup>4</sup> recommended value of 0.90 for a good fit. TLI value was 0.96 above the 0.90 cut-offs.<sup>5</sup> All these indices suggest a good fit of the uni-dimensional SDATRM scale.

Thus, results suggested that the SDATRM is a reliable and valid scale that can be used with different variables such as religiosity and personality traits to evaluate socially distant attitudes toward religious minorities of Pakistani students. Future study is required to reproduce this result in different populations.

## 6. CONCLUSION

In conclusion, this study has successfully navigated the intricate process of developing and validating the SDATRM with a careful and multi-stage approach. The initial stages involved a comprehensive literature review, item adaptation and generation, and a rigorous refinement to address challenges associated with defining the domain amid prevalent negativity in the existing literature. The study's strength lies in

---

<sup>1</sup> Sengul Cangur Ercan and Ilker. "Comparison of Model Fit Indices Used in Structural Equation Modeling Under Multivariate Normality." *Journal of Modern Applied Statistical Methods* 14, no. 1 (2015): 152-167.

<sup>2</sup> W. W. Chin, and P. A. Todd. "On the Use, Usefulness, and Ease of Use of Structural Equation Modeling in MIS Research." *MIS Quarterly* 19, no. 2 (1995): 237-246.

<sup>3</sup> R. B. Kline. *Principles and practice of structural equation modeling*. Vol. 2 nd. New York: The Guilford Press, 2005.

<sup>4</sup> P.M. Bentler, and D.C. Bonnet. "Significance Tests and Goodness of Fit in the Analysis of Covariance Structures." *Psychological Bulletin* 88, no. 3 (1980): 588-606.

<sup>5</sup> T. A. Brown. *Confirmatory Factor Analysis for Applied Research*. (New York: The Guilford Press, 2006).

its iterative refinement process, ensuring that the SDATRM captures the nuances of socially distant attitudes towards religious minorities in the specific context of Pakistan. The robust psychometric analyses, including EFA and CFA, have provided compelling evidence for the reliability and validity of the SDATRM. The unidimensional structure, high commonalities, and substantial factor loadings underscore the scale's coherence and effectiveness in measuring the intended construct.

Nevertheless, the SDATRM exhibits satisfactory psychometric properties, so it is essential for future research to validate its merits across diverse populations and contexts. The study acknowledges the need for cautious adaptation when applying the scale outside the Pakistani context. The culmination of theoretical and statistical rigor in the development process positions the SDATRM as a significant contribution to the field.

## 7. ETHICAL CONSIDERATION

In this study, we ensured strict adherence to ethical standards. The Board of Advance Studies and Research (BASR) of International Islamic University, Islamabad, approved the research, indicating compliance with ethical guidelines. We obtained written consent from participants before participating in the study, outlining its goals, methods, and possible effects, ensuring they voluntarily agreed to participate in the research.

**Funding:** This research received no external funding.

**Conflicts of Interest:** The authors declare no conflict of interest.

## BIBLIOGRAPHY

- Afzal, Madiha. *Education and Attitudes in Pakistan: Understanding Perceptions of Terrorism*. Special Report 367. Washington, DC: United States Institute of Peace, 2015.
- Ajmal, M. Asir, Safia Sultana, Noor ul Ain, and Marriam Tahira. "Perception of Pakistani Muslim Students Regarding Jews." *Pakistan Journal of Social and Clinical Psychology* 9 (2011): 3-10.
- Alam, Aftab Muhammad, Adnan Rehmat, and Emilie Lehmann Jacobsen. "Narratives of Marginalization: Reporting Religious Minorities in Pakistani Media." Institute for Research, Advocacy, and Development (IRADA), 2018: 1-36.
- Ali, Shahzad, and Jalaluddin. "Portrayal of minorities in elite English press of Pakistan: A study of *Daily Dawn* and *The Nation*." *Pakistan Journal of Social Sciences* 30, no. 1 (2010): 141–156.
- Ambreen, Qandeela. "Representation of Religious Minorities in Pakistani Print Media: A study of *Daily Dawn*, *The News*, and *The Nation*." *American International Journal of Contemporary Research*, 2014: 140-156.
- Anthony, Kashif, and Zahid Hussain. "Social media stoking religious hatred in Pakistan." *Union of Catholic Asian News*. September 17, 2018. [Link](#) (accessed March 10, 2023).
- Bentler, P.M. and Bonnet, D.C. "Significance Tests and Goodness of Fit in the Analysis of Covariance Structures." *Psychological Bulletin* 88, no. 3 (1980): 588-606.
- Boateng, Godfred O., Torsten B. Neilands, Edward A. Frongillo, Hugo R. Melgar-Quinonez and Sera L. Young. "Best Practices for Developing and Validating Scales for Health, Social, and Behavioral Research: A Primer." *Front Public Health*, no. 6: 149 (June 2018).
- Brigham, John C. "College Students' Racial Attitudes." *Journal of Applied Social Psychology*, no. 23 (1993): 1933 – 1967.
- Brown, T. A. *Confirmatory Factor Analysis for Applied Research*. (New York: The Guilford Press, 2006.)
- Bushra, S. "Cue the curtain on Pakistani Minorities." *The Dawn*. August 3, 2011. [Link](#) (accessed March 10, 2023).
- Chaudhry, Kamran. "Minorities Marginalized by Pakistan's media." *Union of Catholic Asian News*. February 05, 2019. [Link](#) (accessed February 10, 2023).
- Chin, W. W., & Todd, P. A. "On the Use, Usefulness, and Ease of Use of Structural Equation Modeling in MIS Research." *MIS Quarterly* 19, no. 2 (1995): 237-246.
- Clark, Lee Anna, and Watson, David. "Constructing Validity: Basic Issues in Objective Scale Development." *The American Psychological Association* 7, no. 3 (1995): 309-319.
- DeVellis, Robert F. *Scale Development: Theory and Applications*. (Los Angeles: SAGE Publications, 2017).

- Ercan, Sengul Cangur & Ilker. "Comparison of Model Fit Indices Used in Structural Equation Modeling Under Multivariate Normality." *Journal of Modern Applied Statistical Methods* 14, no. 1 (2015): 152-167.
- Farooq, Yasir, and Ihsan-ur-rehman Ghauri. "Inequalities in Islamic State and Society (A Critical Review on the Thoughts of Bernard Lewis)." *Journal of Islamic & Religious Studies* 2, no. 2 (2017): 33–44. <https://doi.org/doi.org/10.36476/JIRS.2:2.12.2017.17>.
- Farooq, Yasir, and Inamullah Wattu. "The Socioeconomic Sphere of Muslim Women-A Critical Study on John L. Esposito's Views." *Journal of Religious Studies* 2, no. 1 (2018): 58–69. <https://jrs.uoch.edu.pk/index.php/journal3/article/view/97>.
- Farooq, Yasir, and Muhammad Mansha Tayyab. "Impacts of Psychological and Domestic Violence on Women in Pakistan: Problems & Solutions in the Light of Islamic Teachings." *IQAN* 1, no. 2 (2019): 1–16. <https://www.iqan.com.pk/index.php/iqan/article/view/45>.
- Faruqi, Mariam. *A Question of Faith: A Report on the Status of Religious Minorities in Pakistan*. Islamabad: Jinnah Institute, 2011, 4-70.
- Fuchs, Maria-Magdalena., & Fuchs, Simon Wolfgang. "Religious Minorities in Pakistan: Identities, Citizenship and Social Belonging." *South Asia: Journal of South Asian Studies* 43, no. 1 (2020): 52-67.
- Furr, R. Michael. *Scale Construction and Psychometrics for Social and Personality Psychology*. (New Delhi: Sage Publications, 2011).
- Gregory, Shaun R, and Simon R Valentine. *Pakistan: The Situation of Religious Minorities*. Geneva: United Nations High Commissioner for Refugees, 2009, 1-41.
- Hadi, Noor Ul., Abdullah, Naziruddin. and Sentosa, Ilham. "An Easy Approach to Exploratory Factor Analysis: Marketing Perspective." *Journal of Educational and Social Research* 6, no. 1 (2016): 215-223.
- Hair, Joseph F., Black, William C., Babin, Barry J., and Anderson, Rolph E. *Multivariate Data Analysis*. 7th. (Edinburgh: Pearson Education Limited, 2014).
- Henson, Robin K., and J. Kyle Roberts. "Use of Exploratory Factor Analysis in Published Research: Common Errors and Some Comment on Improved Practice." *Educational and Psychological Measurement* 66, no. 3 (2006): 393–416.
- Hussain, Azhar, Ahmad Salim, and Arif Naveed. *Connecting the Dots: Education and Religious Discrimination in Pakistan, A Study of Public Schools and Madrassas*. Washington, D.C.: United States Commission on International Religious Freedom, 2011.
- International Media Support. "Religious Minorities Overlooked in Pakistan's Mainstream Media." *International Media Support*. July 04, 2019. [Link](#) (accessed February 9, 2023).

- Iqbal, Shahid, Riaz Ahmad, and Nadia Ayub. "Level of Depression among Adolescents of Religious Minorities and their Dominant Counterparts in Pakistan." *Journal of Child and Adolescent Mental Health* 24, no. 2 (2012): 163-171.
- Iqbal, Shahid, Riaz Ahmad, and Nadia Ayub. "Self-esteem: A Comparative Study of Adolescents from Mainstream and Minority Religious Groups in Pakistan." *Journal of Immigrant and Minority Health* 15, no. 1 (2013): 49-56.
- Islamabad Policy Research Institute. *Rights of Religious Minorities in South Asia: Learning from Mutual Experiences*. Islamabad: Islamabad Policy Research Institute, 2012.
- Kaiser, Henry F. "An index of Factorial Simplicity." *Psychometrika*, no. 39 (1974): 31-36.
- Kelme, R. B. "Exploratory and Confirmatory Factor Analysis." In *Applied Quantitative Analysis in Education and Social Sciences*, edited by C. Schatschneider and D. L. Compton Y. Petscher, 171-207. (New York: Routledge, 2013).
- Khalid, Iram, and Maqbool Anwar. "Minorities under Constitution(s) of Pakistan." *Journal of Research Society of Pakistan* 55, no. 2 (2018): 51-62.
- Khan, Zeeshan Ali. "Media Coverage Provided to Religious Minorities: A Study on Pakistani Print Media Since 2011 to 2015." *International Journal of Applied Sciences* 1, no. 4 (2016): 30-44.
- Kline, R. B. *Principles and practice of structural equation modeling*. Vol. 2nd. (New York: The Guilford Press, 2005).
- Mehmood, Zafar ul-Islam, Munawar S Mirza, Khuda Bakhsh Khan, Muhammad Shahbir, and Sagheer Iqbal. "Discrimination and Problems of Religious Minority Students in Public Schools of Pakistan." *Journal of Education Research and Behavioral Sciences* 3, no. 8 (2014): 237-239.
- Mubeen, Amber, and Rabia Qusien. "Minorities in Pakistan: Role of Pakistani Private TV Channels in Highlighting Minorities' Rights." *Online Journal of Communication and Media Technologies* 7, no. 2 (2017): 96-103.
- Mughal, Aftab Alexander. "On the Catalogue of Injuries Faced by Religious Minorities in Pakistan." *Open Democracy*. January 25, 2018. [Link](#) (accessed March 12, 2023).
- Mustafa, Ghulam, Tooba Ahmad, and Muhammad Arslan. "Minorities of Pakistan: An Analytical Analysis of the 1973 Constitution of Islamic Republic of Pakistan." *Pakistan Social Sciences Review* 4, no. 2 (2020): 736-750.
- Naveed, Fouzia, Maryam Munir, and Yasir Saeed. "Unveiling the Situation of Religious Minorities: A Case Study of Marginalized Groups Living in Lahore." *International Journal of Asian Social Science* 4, no. 1 (2014): 41-50.
- Naz, Afsheen. *Attitude of Female Teachers towards Religious Minorities: A Case Study of KPK Female Madrasahs*. (Working Paper No 123), Islamabad: Sustainable Development Policy Institute, 2011.
- Pakistan Bureau of Statistics. *Population by Religion*. (Islamabad: Pakistan Bureau of Statistics, 2017).

- Pakistan Institute of Labour Education & Research. *The Choice of Reforms: The Human Rights Situation of Ethnic, Linguistic, Religious Minorities, Scheduled Castes Hindus and Indigenous people in Pakistan*. Karachi: Pakistan Institute of Labour Education & Research, 2009.
- Parasuraman, A., Zeithaml, V. and Malhotra, A. "E-S-Qual: A Multiple-item scale for Assessing Electronic Service Quality." *Journal of Service Research*, Vol.7, No.3, 7, no. 3 (2005): 213-233.
- Pew Research Center (PRC). "Religious Hostilities Reach Six-Year High." *Pew Research Center*. January 14, 2014. [Link](#) (accessed May 10, 2023).
- Poza, Rebecca Buckwalter. "Pakistan's Institutionalized Discrimination Against Religious Minorities." *HuffPost*. May 25, 2011. [Link](#) (accessed March 8, 2023).
- Raheem, Muhammad Arslan. "A Comparative Study of the Attitudes of Students Attending Urdu Medium, English Medium and Seminary Schools in Pakistan." (PhD Thesis, University of Glasgow, Glasgow, 2015).
- Rahman, Tariq. "Pakistan's Policies and Practices Towards the Religious Minorities." *South Asian History and Culture* 3, no. 2 (2012): 302-315.
- Rahman, Tariq. "Pluralism and Intolerance in Pakistani Society: Attitudes of Pakistani Students towards Other Religious." *Conference on Pluralism*. Karachi: Aga Khan University Institute for the Study of Muslim Civilization, 2003.
- Shaikh, Hina. *Status of Minorities in Pakistan in 2010: Annual Report*. Colombo: South Asians for Human Rights, 2011.
- Shehzadi, Sidra. "Coverage of Minority Issues in the Pakistani Electronic Media." *International Journal of Advance Research*, 2017: 1903-1910.
- Tamsut, Felix. "IStandWithAhmadis: Pakistanis show support for religious minority on social media." *DW Akademie*. December 2, 2015. [Link](#) (accessed May 10, 2023).
- Tanveer, Rana. "Social media being used as tool against minorities." *The Express Tribune*. December 22, 2016. [Link](#) (accessed May 10, 2023).
- United States Commission on International Religious Freedom. "USCIRF Annual Report 2016 - Tier 1 CPCs recommended by USCIRF-Pakistan." *refworld*. May 2, 2016. [Link](#) (accessed Nov 25, 2023).
- United States Commission on International Religious Freedom. "USCIRF Annual Report 2018 - Tier 1: USCIRF-recommended Countries of Particular Concern (CPC) - Pakistan." *Refworld*. April 25, 2018. [Link](#) (accessed Nov 25, 2023).
- United States Commission on International Religious Freedom. *Annual Report 2012*. Washington, D.C: United States Commission on International Religious Freedom, March 2012.
- United States Commission On International Religious Freedom. *Teaching Intolerance in Pakistan: Religious Bias in Public School Textbooks*. Islamabad: United States Commission On International Religious Freedom, 2016, 1-19.

- 
- Urbina, Susana. *Essentials of Psychological Testing*. (New Jersey: John Wiley & Sons, Inc, 2004).
- Verberk, G., Scheepers, P., & Felling, A. "Attitudes and Behavioural Intentions towards Ethnic Minorities: An Empirical test of Several Theoretical Explanations for the Dutch case." *Journal of Ethnic and Migration Studies* 28, no. 2 (2010): 197-219.
- Walker, Lain. "Attitudes to Minorities: Survey Evidence of Western Australians' Attitudes to Aborigines, Asians, and Women." *Australian Journal of Psychology* 46, no. 3 (1994): 137-143.
- Wattoo, Inam Ullah, and Yasir Farooq. "Fundamental Human Rights and UNO Charter: A Critical Analysis with Islamic Perspectives." *Journal of Religious Studies (UOCHJRS)*, 2021. <https://doi.org/10.33195/journal.v4i02.338>.
- William G. Zikmund, Barry J. Babin, Jon C. Carr, Mitch Griffin. *Business Research Methods*. 9th. (Boston: Cengage Learning, 2013).